

Stromsensoren auf Hallsensorbasis im SOIC-8 Gehäuse

First SOIC8-Packaged Hall-Effect Current Sensor with Integrated Current Path

The newest current sensor family from Allegro MicroSystems, Inc., the [ACS704](#), is the first SOIC8-packaged Hall-effect current sensor with the current path integrated into the package for greater sensitivity and accuracy. Available in both 15 A and 5 A versions, it measures bi-directional ac or dc currents by using a Hall-effect magnetic field sensor to measure the field generated by the current flow. Because there is no electrical connection between the current path and sensing circuit, it provides a minimum of 800 volts of isolation without the use of additional components.

Only 1.7 mm high, the ACS704 provides a monolithic solution that is much smaller than other integrated current path Hall-effect sensors with comparable sensitivity, and with greater accuracy, sensitivity, and creepage and clearance distances than "trace-straddling" sensors.

Accuracy at 25°C typically exceeds 1.5%, and the sensor is compliant to lead-free directives. The 1.5 mohm resistance of the sensor provides extremely low power loss and voltage drop. The sensor operates from a single, +5V supply, and the output is ratiometric to the supply voltage.

This new current sensor is targeted to meet the needs of the industrial, consumer, communications and automotive markets. End applications including motor control and protection, small electric vehicles, battery monitoring and charge control, power distribution and monitoring, and personal UPS systems.

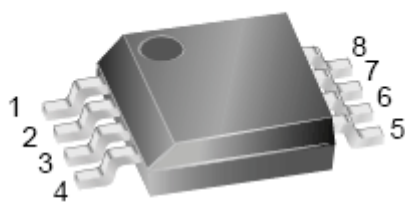

Pin 1: IP+
Pin 2: IP+
Pin 3: IP-
Pin 4: IP-

Pin 5: GND
Pin 6: VOUT
Pin 7: VOUT
Pin 8: VCC

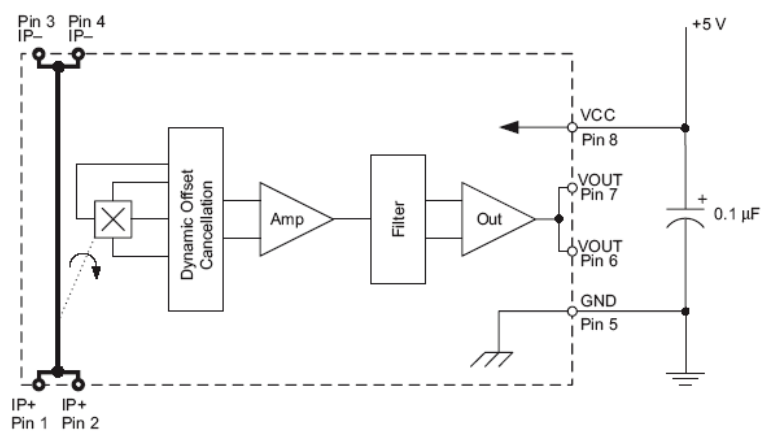

Product Description:

The Allegro ACS704 family of current sensors provides economical and precise solutions for current sensing in industrial, automotive, commercial, and communications systems. The device package allows for easy implementation by the customer. Typical applications include motor control, load detection and management, switched mode power supplies, and over current fault protection.

The device consists of a precision linear Hall sensor circuit with a copper conduction path located near the surface of the die. Applied current flows through this primary conduction path and the Hall sensor responds to the magnetic field generated by this applied current. Device sensitivity is maximized by this arrangement because the Hall element is situated in extremely close proximity to the current being measured. Precision factory programming of the linear Hall sensor results in high-level performance and product uniformity.

The internal resistance of the conductive path used for current sensing is typically 1.5 milli-ohms, providing low power loss. The terminals of the conductive path (from pins 1 and 2 to pins 3 and 4) are electrically isolated from the sensor leads (pins 5 through 8). This allows the ACS704 family of sensors to be used in applications requiring electrical isolation, where it eliminates the need for additional opto-isolators or other costly isolation techniques.

The output of the device has a positive slope ($>V_{CC}/2$) when an increasing current flows through the conductive path from pins 1 and 2 to pins 3 and 4.
